



**BLM0
DC LATCHING SOLENOID**

Availability
DC only
PULL - THRUST - PULL & THRUST

Solenoid shown in energised position

Weight complete 20g
Plunger weight 4g max

Solenoid CLOSSES with **RED** Lead + VE
Solenoid OPENS with **BLACK** Lead + VE

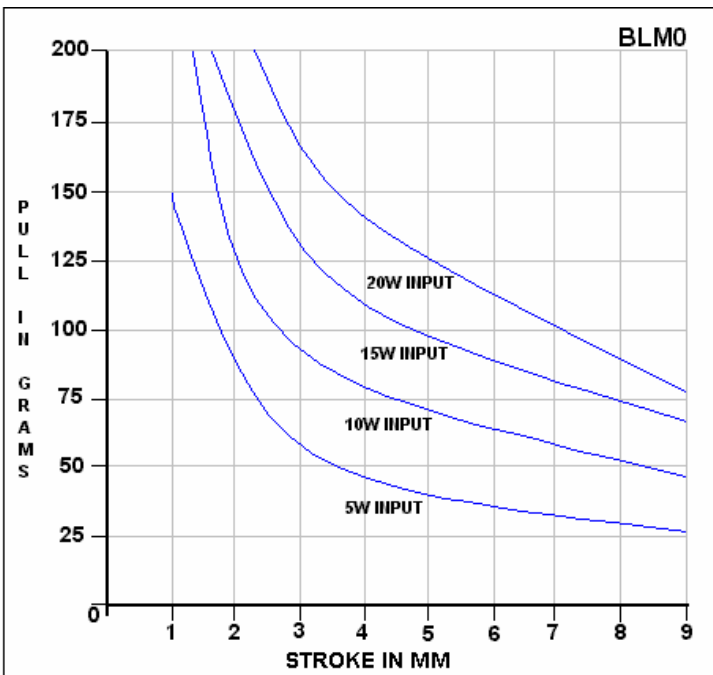
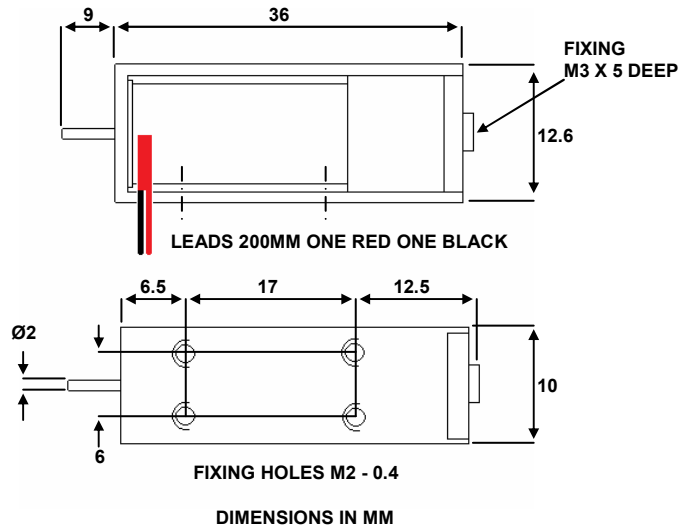

Minimum Pulse duration - 50ms
Delatch power 0.5W

Forces shown are at working temperature
Cold forces are higher

HE & BS Benson Ltd

1 Laureate Industrial Estate, Exning Road, Newmarket, Suffolk CB8 0AR
 Tel. +44 (0) 1638 663535 / 663130 Fax. +44 (0) 1638 667434
 sales@hebsbenson.co.uk - technical@hebsbenson.co.uk