

HE & BS Benson Ltd

Solenoids & Electromagnets



- AC & DC Linear
- DC Latching
- Industrial
- Electromagnets



HE & BS Benson Ltd
1 Laureate Industrial Estate
Exning Road
Newmarket
Suffolk UK
CB8 0AR

T. +44(0)1638 663535 — 663130
F. +44(0)1638 667434
E. sales@hebsbenson.co.uk
www.hebsbenson.co.uk



Products

Overview

Page

Solenoid Fundamentals
3 & 4

AC & DC Linear - Open Frame

Simple and robust, cost effective for a variety of applications.

- 5. B0 (DC)
- 6. CLP3 (DC)
- 7. B1 (DC)
- 8. B2 (AC & DC)
- 9. B3 (AC & DC)
- 10. B4 (AC & DC)
- 11. B5 (AC & DC)
- 12. B6 (DC)
- 13. B7 (DC)
- 14. B8 (DC)



DC Latching

A combination of an electromagnetic solenoid and permanent magnets.

- 15. BLM0
- 16. BLM3
- 17. BLM5



Industrial

Cylindrical design, robust construction and IP40 protection - suitable for many automation processes.

- 18. CLP10
- 19. CLP12
- 20. CLP14



Electromagnets

Holding force Power On and Power Off

21.



Special / Custom Made

22.



HE & BS Benson Ltd
1 Laureate Industrial Estate
Exning Road
Newmarket
Suffolk UK
CB8 0AR

T. +44(0)1638 663535 – 663130
F. +44(0)1638 667434
E. sales@hebsbenson.co.uk
www.hebsbenson.co.uk



Solenoid Fundamentals

The main factors in a solenoid application are:

- To Pull or to Thrust
- Stroke (length of travel)
- Force Required
- Rating
- Supply (AC, DC and variations)
- Voltage
- Ambient Temperature

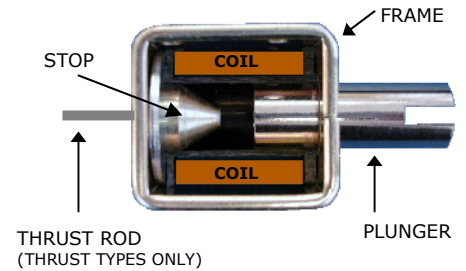
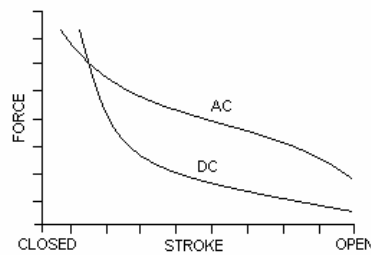

1, A Solenoid is a linear actuator, which PULLS the plunger toward the stop when the coil is energised. It can only PULL, though a return spring can be fitted if required. To make it Thrust (PUSH) it must have a non-magnetic thrust rod.

2, Force increases as it closes - see graph above, note the difference between AC and DC solenoids. AC solenoids are more powerful than DC on the longer strokes but there are Long Stroke DC types designed for best possible long stroke force. (See data sheets).

3, You decide the stroke - this is set by the way the solenoid is mounted relative to the mechanism it has to operate.

4, Plungers are not captive - a solenoid should be fitted so that the plunger cannot drop out. The maximum practical stroke is shown on its force curve

RATING

A solenoid can be made more powerful by fitting a coil, which takes higher watts. It will get hotter; so will need to cool between each operation. Solenoid manufacturers use the '%' rating for higher force solenoids

Watts = heat, and on intermittent ratings there is a limit to the time a coil can safely carry the higher power. This 'maximum time energised' depends on the rating, size of solenoid, and any 'heat sink' benefit gained from the mounting. Note that % ratings are simply a convenient system which covers most applications; coils can be wound for other duties if required.

DUTY CYCLE

$$\% = \frac{\text{Time On}}{\text{Time On} + \text{Time Off}} \times 100$$

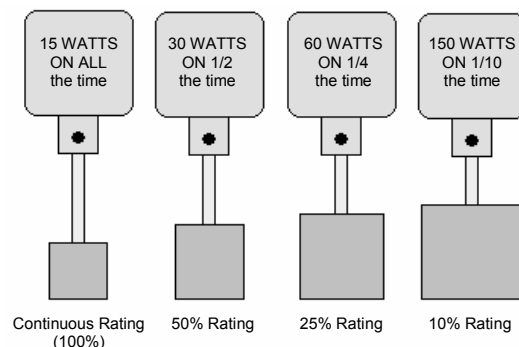

HE & BS Benson Ltd
1 Laureate Industrial Estate
Exning Road
Newmarket
Suffolk UK
CB8 0AR

T. +44(0)1638 663535 – 663130
F. +44(0)1638 667434
E. sales@hebsenson.co.uk
www.hebsenson.co.uk



Solenoid Fundamentals

HEATING

A solenoid is more powerful cold, than hot. This is because the coil resistance increase as it warms up, reducing the current and therefore the force. The cold/hot differences are less on AC than on a DC solenoid. Note; our force curves show the coil at maximum working temperature.

AMBINET TEMPERATURE

In a high ambient temperature or a total enclosure a lower-watts, lower force coil is the conventional way of keeping coil temperature within the safe limit. Coils are normally designed for a temperature rise of about 75°C due to self-heating and we assume an ambient temperature of 20°C.

AC INRUSH CURRENT

An AC solenoid draws a current surge as it closes. The longer the stroke, the greater the surge. On fast cycling, these repeated surges increase the coil heating and upset the ‘% rating’ principle of higher force for intermittent duty. Sometimes a lower than continuous rating is necessary to avoid too high a temperature rise from repeated inrush current. This uses a DE-RATED coil and gives less than continuous force. There is no DC INRUSH CURRENT. All DC Intermittent duties can be based on the % rating principle subject to the ‘maximum time energised’.

RECIFIED SUPPLY

DC solenoids are often supplied from rectifiers. Ripple current can cause hum unless adequately smoothed . Full-wave rectification is better than half-wave. For some intermittent duties however unsmoothed half-wave may be acceptable.

SOLENOID SIZE

If you are tempted to use the smallest solenoid that will do your job, remember that it will take more current than a larger one. As an extreme example, a BDC2 would take 50 watts (cold) to pull 340g, through 10mm, where as a BDC5 would take only 7 watts. If you need to keep the current down, it makes good sense to step up the solenoid size.

HE & BS Benson Ltd
1 Laureate Industrial Estate
Exning Road
Newmarket
Suffolk UK
CB8 0AR

T. +44(0)1638 663535 – 663130
F. +44(0)1638 667434
E. sales@hebsbenson.co.uk
www.hebsbenson.co.uk



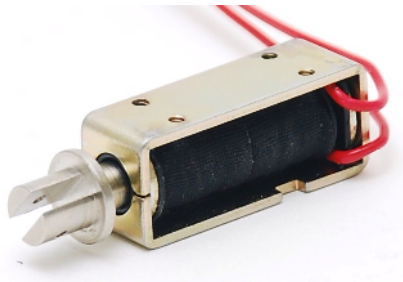

BDC.0
DC LINEAR SOLENOID

Availability
For DC only.
PULL - THRUST - PULL & THRUST
For operation over 50V
please enquire as to feasibility.

Solenoid shown in energised position

Weight complete 19g
Plunger weight 4g max

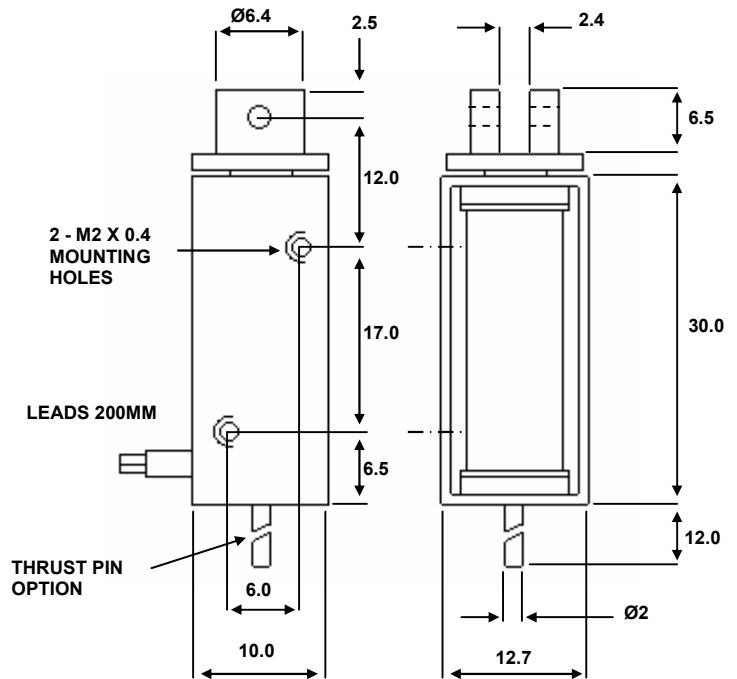

DIMENSIONS IN MM

BDC0

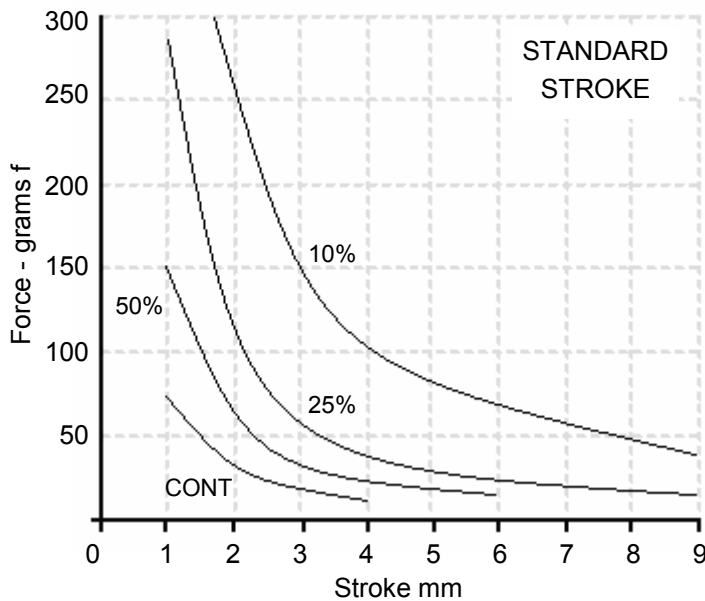

Forces shown are at working temperature
Cold forces are higher

DC Watts
Cont Rtg = 2W
50% Rtg = 4W
25% Rtg = 8W
10% Rtg = 20W

HE & BS Benson Ltd

1 Laureate Industrial Estate, Exning Road, Newmarket, Suffolk CB8 0AR
Tel. +44 (0) 1638 663535 / 663130 Fax. +44 (0) 1638 667434
sales@hebsbenson.co.uk - technical@hebsbenson.co.uk



**CLP.3
DC LINEAR SOLENOID**

Availability
For DC only.
PULL - THRUST - PULL & THRUST
For operation over 50V
please enquire as to feasibility.

Solenoid shown in energised position

Weight complete 70g
Plunger weight 7g max

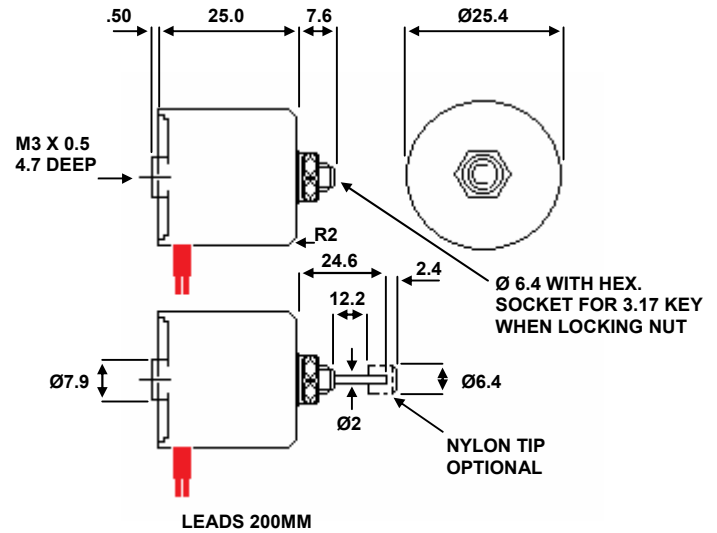

DIMENSIONS IN MM

CLP3

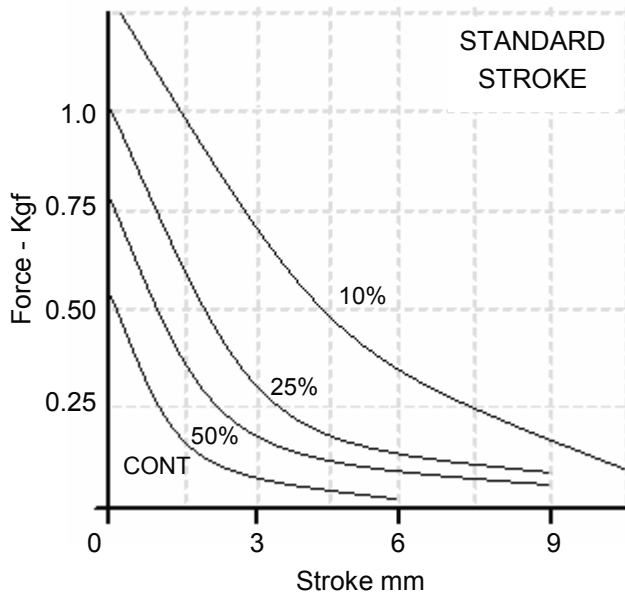

Forces shown are at working temperature
Cold forces are higher

DC Watts
Cont Rtg = 3.5W
50% Rtg = 7W
25% Rtg = 14W
10% Rtg = 35W

HE & BS Benson Ltd

1 Laureate Industrial Estate, Exning Road, Newmarket, Suffolk CB8 0AR
Tel. +44 (0) 1638 663535 / 663130 Fax. +44 (0) 1638 667434
sales@hebsbenson.co.uk - technical@hebsbenson.co.uk

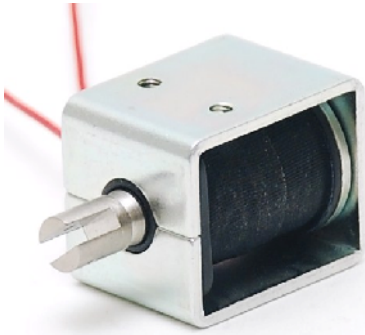

BDC.1
DC LINEAR SOLENOID

Availability
For DC only.
PULL - THRUST - PULL & THRUST
For operation over 50V
please enquire as to feasibility.

Solenoid shown in energised position

Weight complete 55g
Plunger weight 5g max

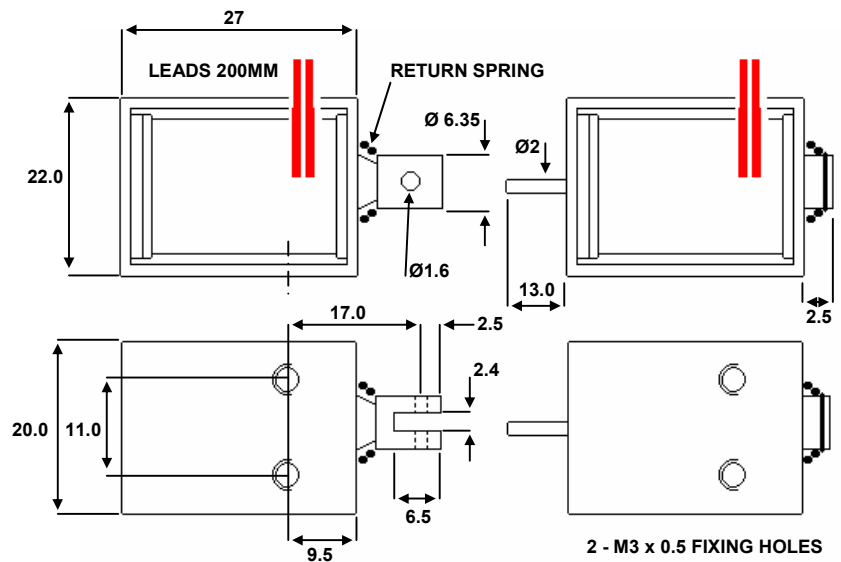

DIMENSIONS N MM

2 - M3 x 0.5 FIXING HOLES

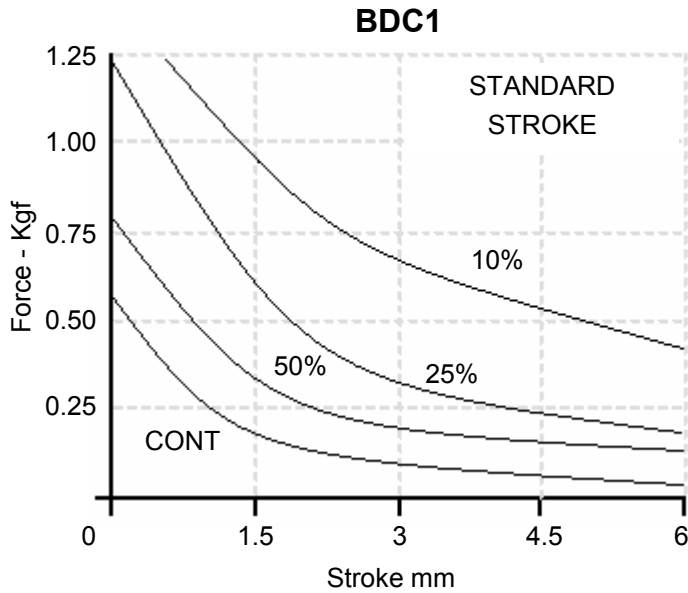

Forces shown are at working temperature
Cold forces are higher

DC Watts
Cont Rtg = 3.75W
50% Rtg = 7.5W
25% Rtg = 15W
10% Rtg = 37.5W

HE & BS Benson Ltd

1 Laureate Industrial Estate, Exning Road, Newmarket, Suffolk CB8 0AR
Tel. +44 (0) 1638 663535 / 663130 Fax. +44 (0) 1638 667434
sales@hebsbenson.co.uk - technical@hebsbenson.co.uk



B2
AC & DC LINEAR SOLENOID

Availability
AC or DC
PULL - THRUST - PULL & THRUST
Side Mount Fixing
For quiet hold, use DC
For operation over 50V
please enquire as to feasibility.

Solenoid shown in energised position

Weight complete 57g
Plunger weight 10g max

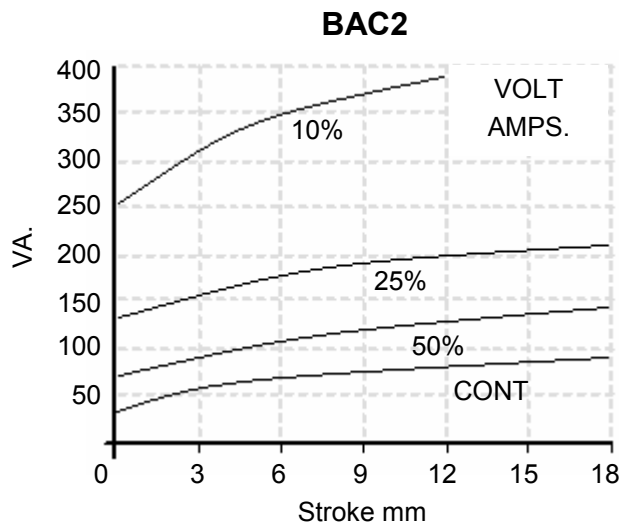
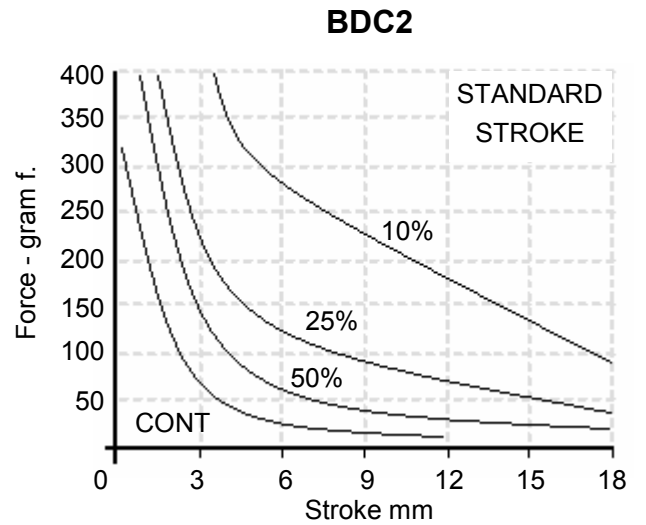
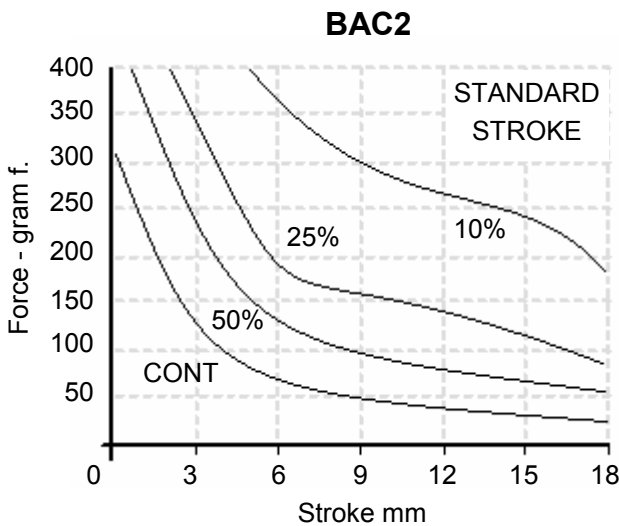
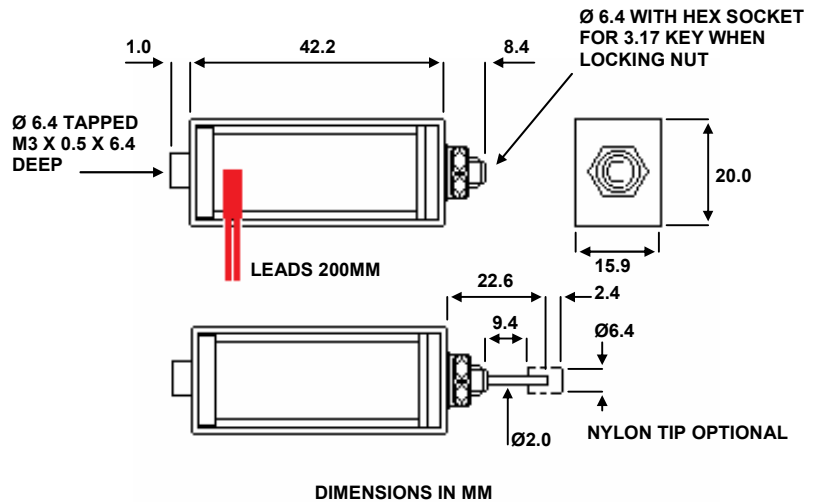

AC Closed VA
Cont Rtg = 6.5VA
50% Rtg = 14VA
25% Rtg = 24VA
10% Rtg = 50VA

DC Watts
Cont Rtg = 5W
50% Rtg = 10W
25% Rtg = 20W
10% Rtg = 50W

Forces shown are at working temperature
Cold forces are higher

HE & BS Benson Ltd

1 Laureate Industrial Estate, Exning Road, Newmarket, Suffolk CB8 0AR

Tel. +44 (0) 1638 663535 / 663130 Fax. +44 (0) 1638 667434

sales@hebsbenson.co.uk - technical@hebsbenson.co.uk

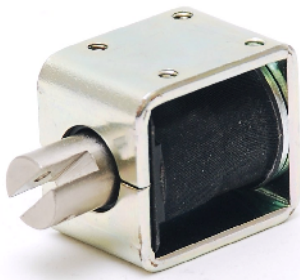

B3
AC & DC LINEAR SOLENOID

Availability
AC or DC Standard Stroke
PULL - THRUST - PULL & THRUST
DC Long Stroke

Solenoid shown in energised position

	Dim 'T'	'S'
BAC3	26	10.5
BDC3	32	16.6

Weight complete 156g
Plunger weight 35g max

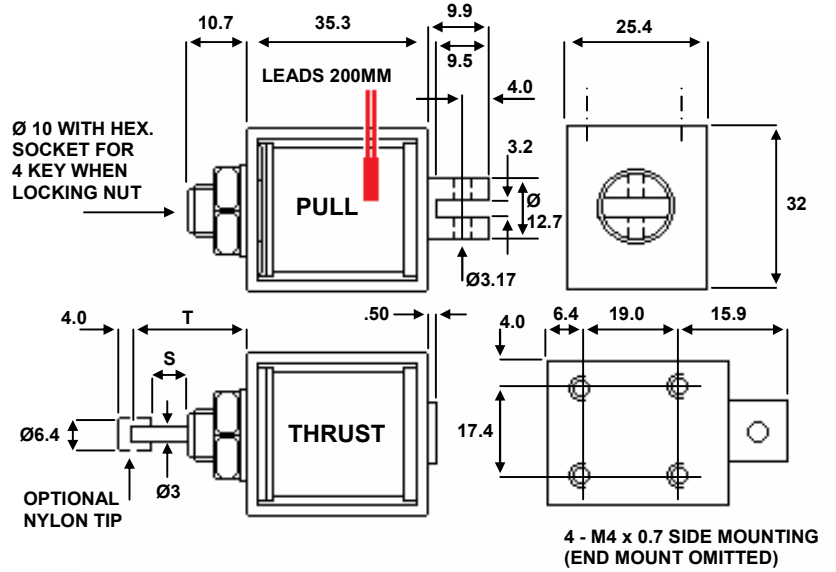

DIMENSIONS IN MM

BAC3

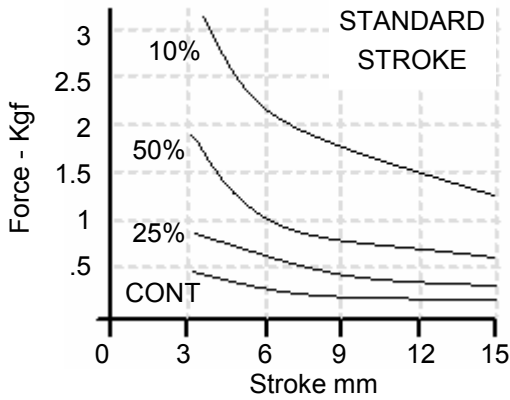

Forces shown are at working temperature
Cold forces are higher

BDC3

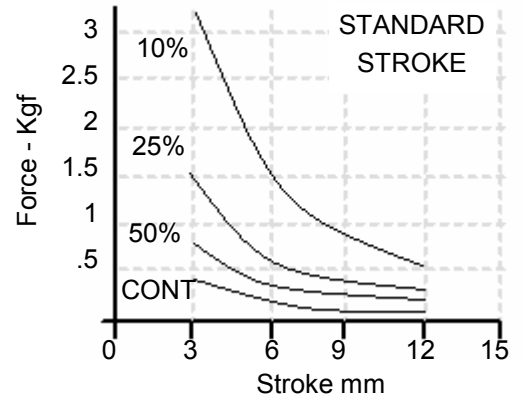

AC Closed VA
Cont Rtg = 9VA
50% Rtg = 20VA
25% Rtg = 40VA
10% Rtg = 100VA

BAC3

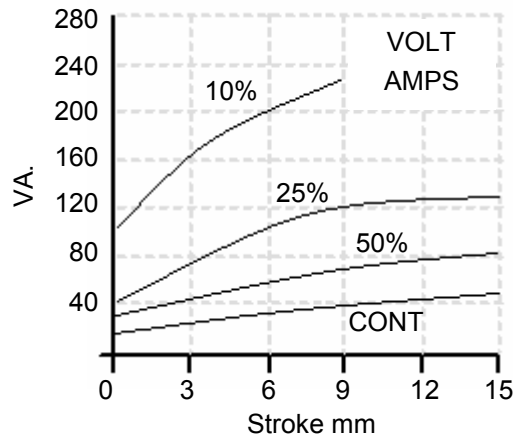

DC Watts
Cont Rtg = 6.5W
50% Rtg = 13W
25% Rtg = 26W
10% Rtg = 65W

BDC3L

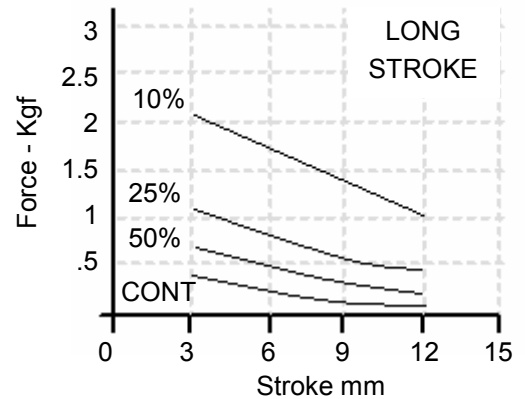

HE & BS Benson Ltd

1 Laureate Industrial Estate, Exning Road, Newmarket, Suffolk CB8 0AR

Tel. +44 (0) 1638 663535 / 663130 Fax. +44 (0) 1638 667434

sales@hebsbenson.co.uk - technical@hebsbenson.co.uk



B4
AC & DC LINEAR SOLENOID

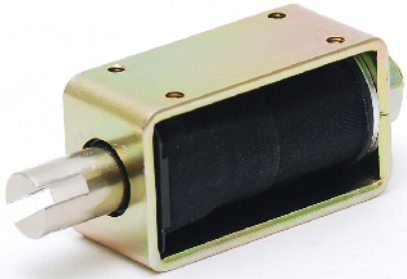

Availability
AC or DC Standard Stroke
PULL - THRUST - PULL & THRUST
DC Long Stroke

Solenoid shown in energised position

	Dim 'T'	Stroke 'S'
BAC4	36.1	20.6
BDC4	32	16.6

Weight complete 248g
Plunger weight 63g max

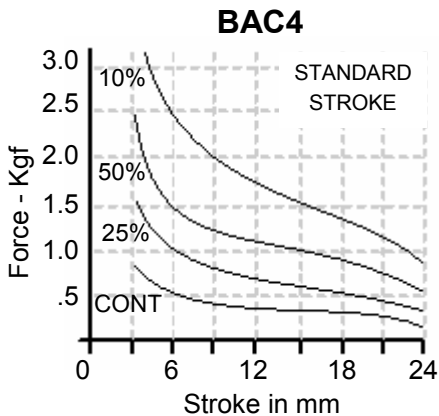
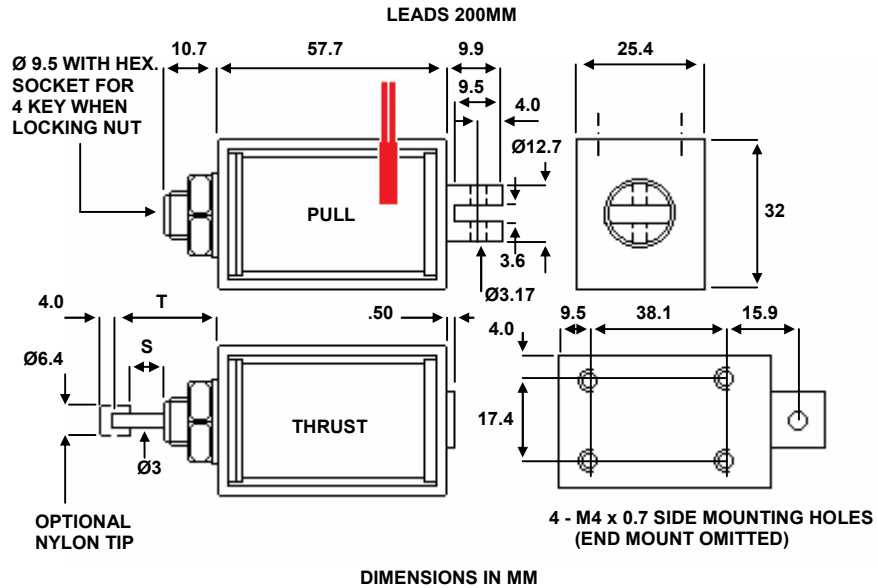

Forces shown are at working temperature
Cold forces are higher

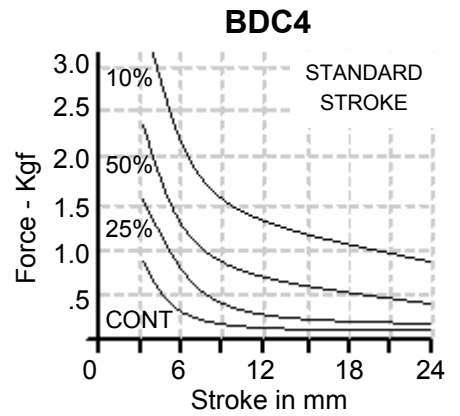

AC Closed VA
Cont Rtg = 17VA
50% Rtg = 34VA
25% Rtg = 68VA
10% Rtg = 200VA

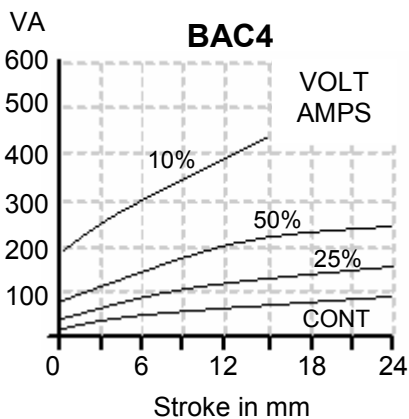
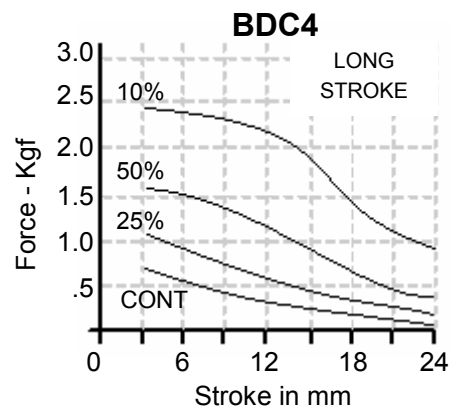

DC Watts
Cont Rtg = 11W
50% Rtg = 22W
25% Rtg = 44W
10% Rtg = 110W

HE & BS Benson Ltd

1 Laureate Industrial Estate, Exning Road, Newmarket, Suffolk CB8 0AR
Tel. +44 (0) 1638 663535 / 663130 Fax. +44 (0) 1638 667434
sales@hebsbenson.co.uk - technical@hebsbenson.co.uk

B5 AC & DC LINEAR SOLENOID

Availability
AC or DC Standard Stroke
PULL - THRUST - PULL & THRUST
DC Long Stroke

Solenoid shown in energised position

Weight complete 566g
Plunger weight 85g max

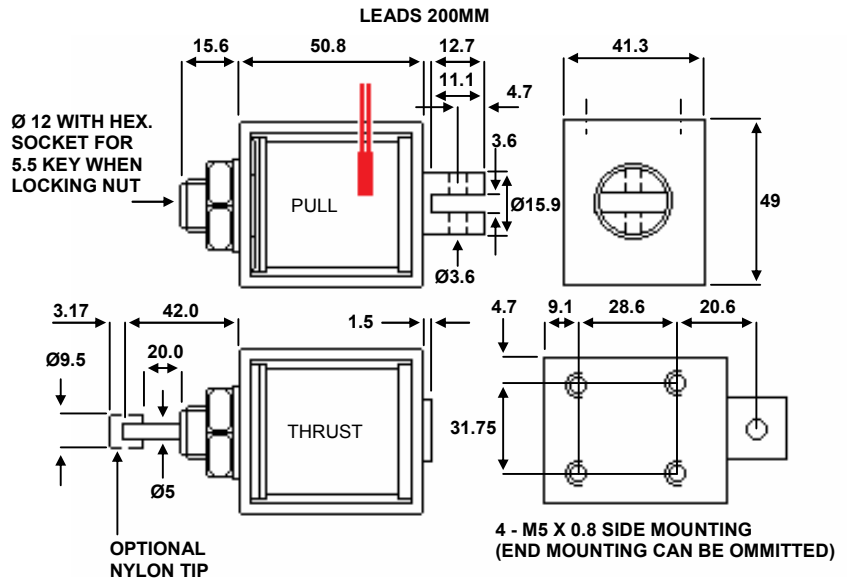

BAC5

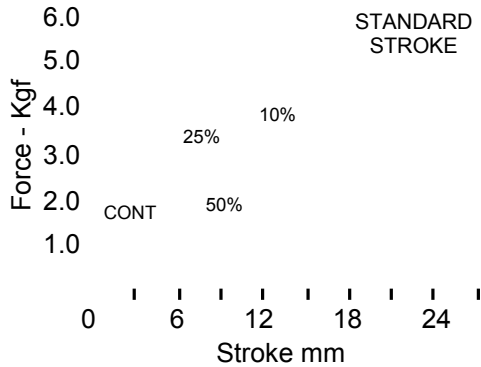

BDC5

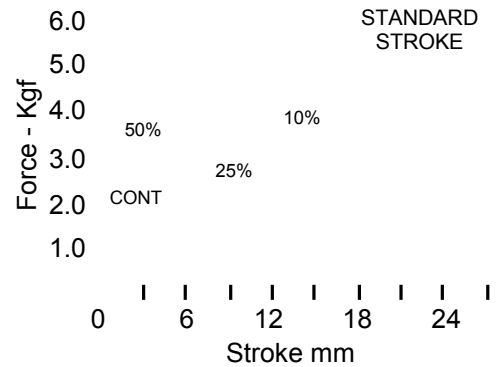

Forces shown are at working temperature
Cold forces are higher

AC Closed VA

Cont Rtg = 30VA
50% Rtg = 70VA
25% Rtg = 120VA
10% Rtg = 300VA

DC Watts

Cont Rtg = 15W
50% Rtg = 30W
25% Rtg = 60W
10% Rtg = 150W

BAC5

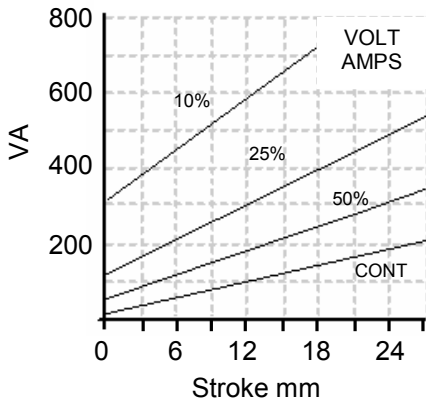

BDC5L

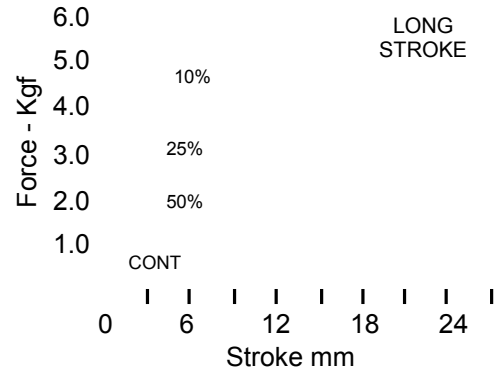

HE & BS Benson Ltd

1 Laureate Industrial Estate, Exning Road, Newmarket, Suffolk CB8 0AR
Tel. +44 (0) 1638 663535 / 663130 Fax. +44 (0) 1638 667434
sales@hebsbenson.co.uk - technical@hebsbenson.co.uk