

**Electromagnetic DOOR HOLDERS**

**Reinforced aluminium housing - with release button**  
**Floor mounting - IP 52**

**SERIES M 8400 D**



**STANDARD FEATURE**

Electromagnetic door holder for fire proof doors, mounted in a reinforced aluminium housing, has a spring loaded device to eliminate the residual magnetism, including the diode of protection, release button and electrical terminal connection.

Series M 8400 electromagnetic door holder is specially designed for use in areas of vandalism (school, colleges, public area...) or industrial area (warehouse, exhibition centre, supermarket, hospital...) or can be suited for every type of fire system protection.

Product individually packed with fitting instructions and white galvanised steel amortized flat keeper plate.

**TECHNICAL SPECIFICATIONS**

<b>Holding force</b>	SERIES M 8400 D	40 daN
<b>Voltage</b>	Available versions :	24 Vdc or 48 Vdc
<b>Nominal power at 20°C</b>	SERIES M 8400 D	2 watt
<b>Electrical protection class</b>		III
<b>Protection rating</b>		IP 52 - EN 60529
<b>Electrical connection</b>		Terminal board
<b>Box colour</b>		Grey RAL 9002 painted steel

Door holders are generally linked to a fire system that will automatically release the doors in case of fire by switching the power off. If required, it can be also manually operated by the release button.

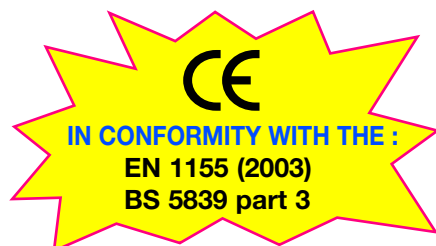

**TECHNICAL DIMENSIONS**

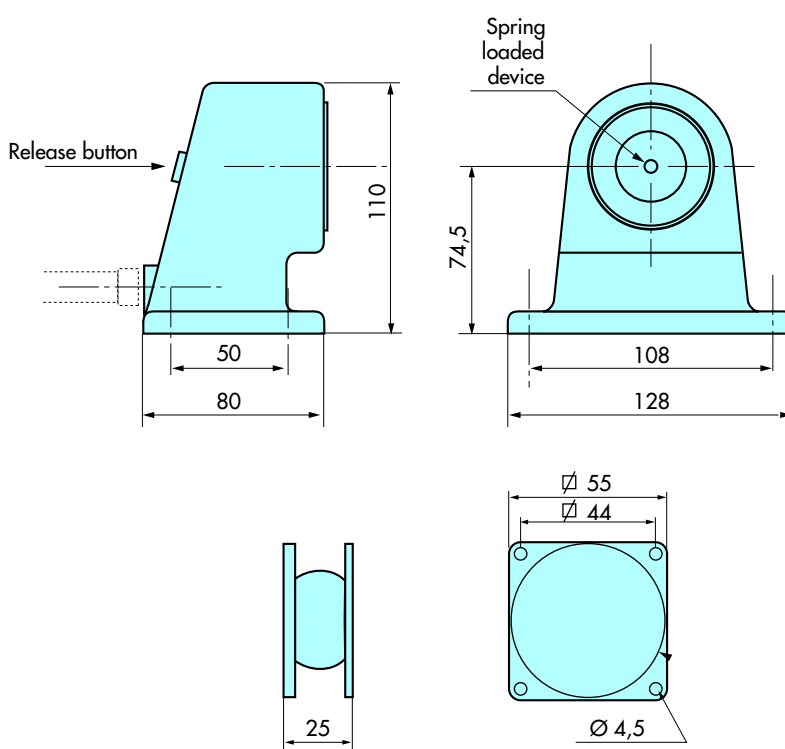
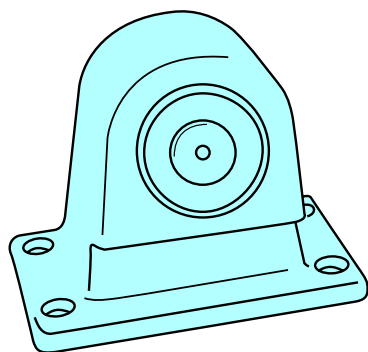

**Electromagnetic DOOR HOLDERS**  
**Reinforced aluminium housing - with release button**  
**Floor mounting - IP 52**

SERIES **M 8400 D**

ITEMS	Holding force	Voltage	Release button	DIODE	Keeper plate
-------	---------------	---------	----------------	-------	--------------

**SERIES M 8400 D**

<b>M 8412 D</b>	40 daN	24 Vdc	YES	YES	FLAT
<b>M 8422 D</b>	40 daN	48 Vdc	YES	YES	FLAT

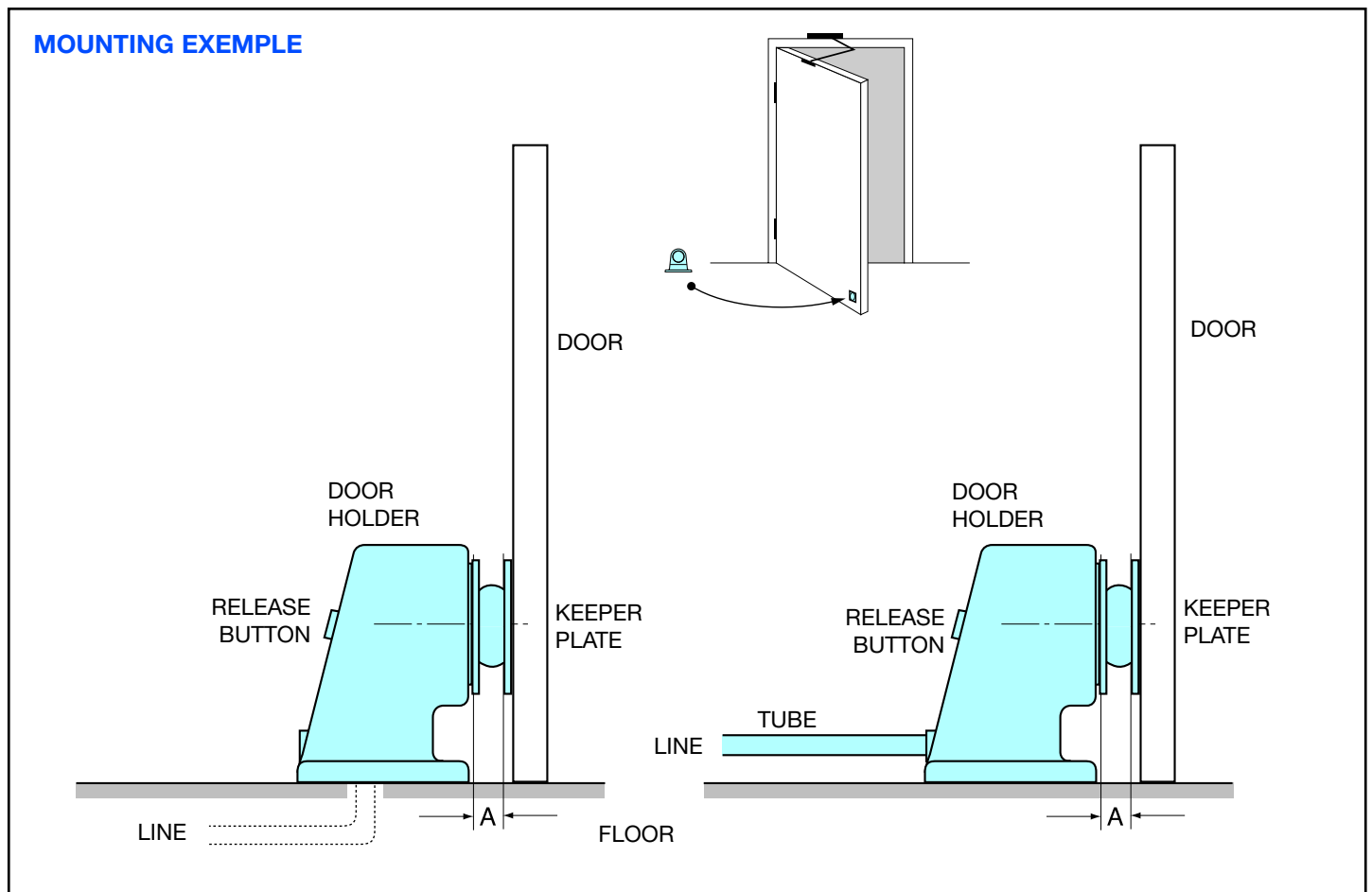

**Please note:**

It must be possible to release a fire protection door held open by an electromagnet with a hand switch which is not hidden by the door. (not included)